

- A - Housing
- B - Retainer
- C - Clamp Plate
- D - Bushing Segment
- E - Radio Spring
- F - Sleeve
- G - Axial Spring

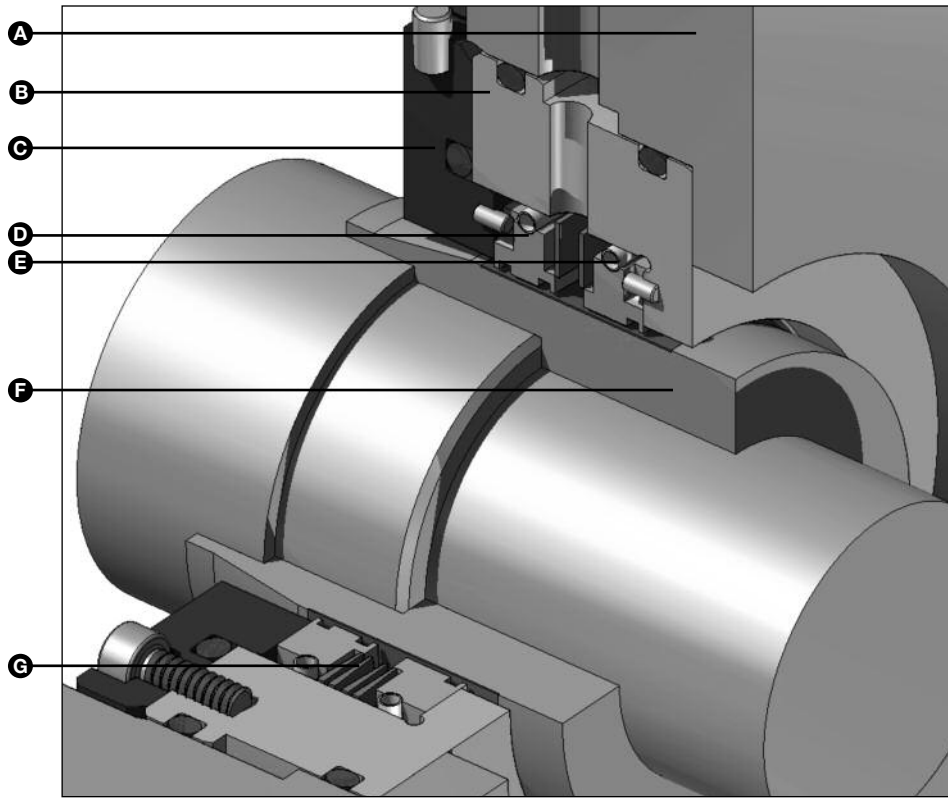

Product Description

The Type 83 is a contacting carbon bushing designed to isolate the bearing oil from the dry gas seal cartridge.

- Normally supplied as a complete seal cartridge, unique inner and outer segments are specifically designed to prevent oil migration and minimize wear.
- Nitrogen is normally injected between the two segmented bushings effectively creating a pressure barrier between the bearing and DGS cavity.
- Advanced materials and design ensure minimal wear and promote long life. Unlike many contacting separation seals the Type 83 is designed to operate on cryogenically dry nitrogen.

Design Features

- Low separation gas consumption.
- Low wear for longer life and improved reliability.
- Cartridge design for easy installation.
- Universal design independent of shaft rotation.
- Unique carbon bushing segment design with self-adjusting hydropads.
- Specially designed segments minimize the separation gas consumption.
- Suitable for running with nitrogen separation gas irrespective of dew point.

Performance Capabilities

- Temperature: -20°F to 400°F / -30°C to 200°C.
- Speed: up to 430 fps / 130 m/s.
- Operating pressure range: 3 to 15 psig / 0.2 to 1.0 bar g.
- Normal separation gas supply pressure: 5 to 7 psi / 0.3 to 0.5 bar.
- Gases: nitrogen, air.
- Vibration levels to API617.

For alternative conditions, consult John Crane.

Required Installation and P&ID for Type 83 Separation Seal

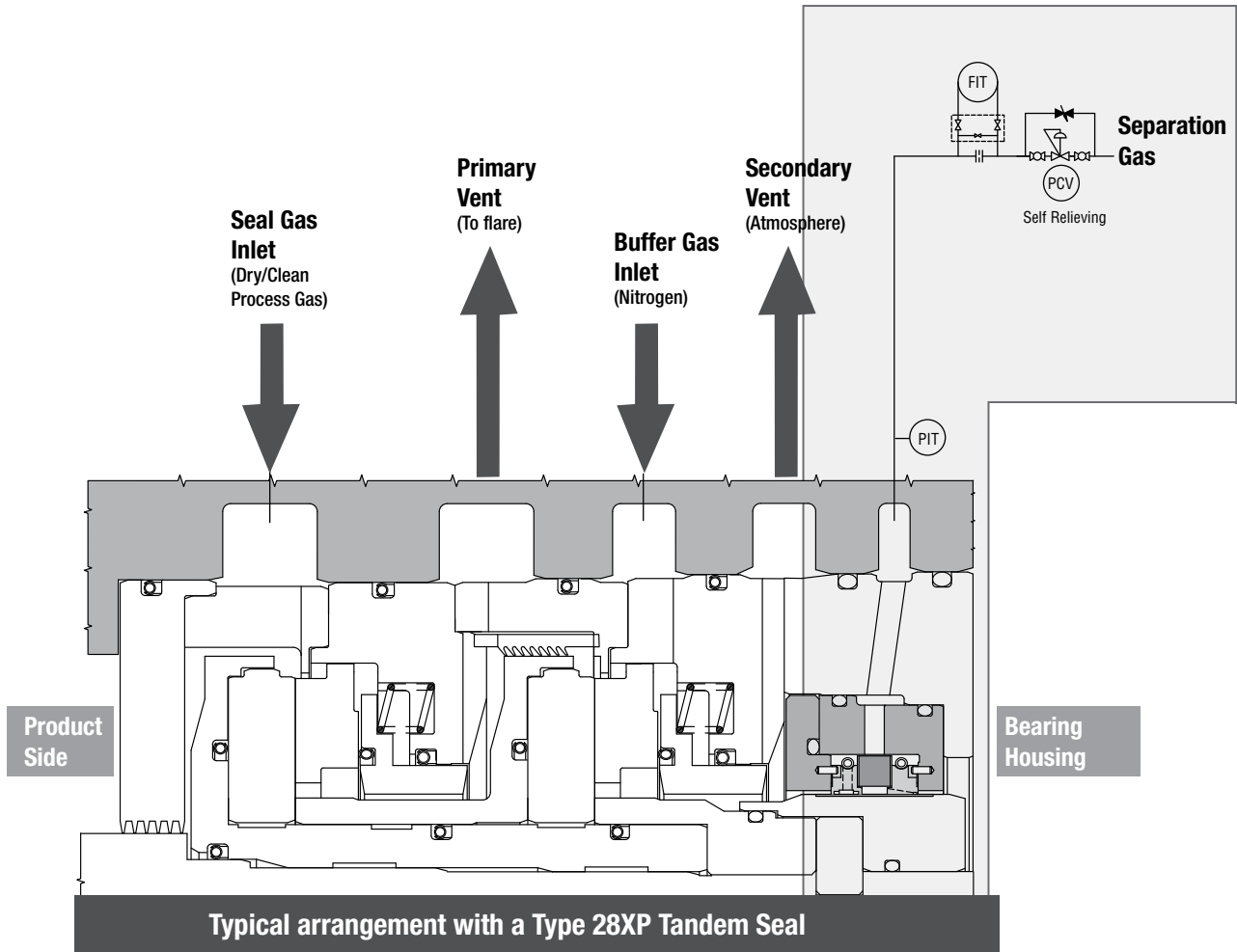



TYPE 83

SEPARATION SEAL

Technical Specification

Materials of Construction

SEAL COMPONENT DESCRIPTION	STANDARD MATERIALS
Bushing Segments	Carbon
Axial Spring	Stainless Steel
Radial Springs	Stainless Steel
Housing Assembly Clamp Plate Assembly	Stainless Steel
Secondary Sealing Elements	Fluoroelastomer

Alternative materials are available, consult John Crane Engineering.

Performance Recommendations

- Separation Gas Specification:
Filtration: 3 microns and dry.
Proper consideration must be given as to the possibility of explosive mixtures.
- Operating Environment:
Vibration levels within API 617.
Bearing housing should be well drained.
Bearing housing should not be pressurized.
Consideration should be given to the secondary vent piping as not to cause an excessive back pressure.
Oil exiting the bearing cavity directed at the separation seal should be noted at design.

Alternative Applications

The Type 83 is normally supplied as a double separation seal as depicted in this data sheet however they can be supplied as individual carbon rings for use on other applications where an effective barrier is required i.e. bearing chambers, fans, blowers, gearboxes and other high speed low pressure applications. Please consult John Crane.



North America
United States of America
Tel: 1-847-967-2400

Europe
United Kingdom
Tel: 44-1753-224000

Latin America
Brazil
Tel: 55-11-3371-2500

Middle East & Africa
United Arab Emirates
Tel: 971-481-27800

Asia Pacific
Singapore
Tel: 65-6518-1800

If the products featured will be used in a potentially dangerous and/or hazardous process, your John Crane representative should be consulted prior to their selection and use. In the interest of continuous development, John Crane Companies reserve the right to alter designs and specifications without prior notice. It is dangerous to smoke while handling products made from PTFE. Old and new PTFE products must not be incinerated. ISO 9001 and ISO14001 Certified, details available on request.